



Catalog Number
Notes
Type

Contractor Select™

JEBL

LED High Bay Light

The JEBL is built to last with 6kV surge protection standard, 55°C ambient temperature rating, and IP65 rated for elimination of dust, moisture and airborne contaminants. Designed for applications including warehousing, gymnasiums, manufacturing and outdoor canopies.

FEATURES:

- Robust 6kV surge protection standard, meeting the ANSI standard for Industrial environments
- Listed for wet locations and IP65 rated to help protect against dust, and airborne contaminants from indoor and outdoor environments



Catalog Number	UPC	Description	Replaces up to	Lumens	Input Watts	CCT	Voltage	Distribution	Pallet Qty.
JEBL 12L 40K 80CRI WH	00191848153840	JEBL LED High Bay	4-lamp T5HO, 6-lamp T8	13,630	95W	4000K	120-277	General	54
JEBL 12L 50K 80CRI WH	00191848153901	JEBL LED High Bay	4-lamp T5HO, 6-lamp T8	13,790	95W	5000K	120-277	General	54

OPERATIONAL DATA

Lumen Package	Color Temperature	Color Rendering Index	Lumens	Wattage	Comparable Light Source:	Product Weight	Package Weight	Ambient temperature
12000LM	40K	80CRI	13,630	95	4-lamp T5HO, 6-lamp T8	7.53 lbs	9.7 lbs	-40° C to 55° C
	50K		13,790					
18000LM	40K	80CRI	19,303	135	6-lamp T5HO, 8-lamp T8, 400W HID	8.79 lbs	10.82 lbs	-40° C to 55° C
24000LM	40K	80CRI	24,181	174	8-lamp T5HO, 400W HID	12.3 lbs	14.98 lbs	-40° C to 50° C
	50K		24,464					

Accessories next page



Specifications

INTENDED USE:

The Lithonia Lighting JEBL LED High bay is an affordable LED solution for users who prefer a luminaire with the look and feel of a round form factor. The JEBL delivers comfortable and uniform lighting for a variety of applications. **Certain airborne contaminants can diminish integrity of acrylic. [Click here for Acrylic Environmental Compatibility table for suitable uses.](#)**

Certain airborne contaminants may adversely affect the functioning of LEDs and other electronic components, depending on various factors such as concentrations of the contaminants, ventilation, and temperature at the end-user location. **[Click here for a list of substances that may not be suitable for interaction with LEDs and other electronic components.](#)**

CONSTRUCTION:

JEBL features a white die-cast aluminum housing. Powder coat corrosion resistant finish provides 500 hours salt fog rating. Optional clear polycarbonate or diffuse aluminum reflectors available separately. Corrosion resistant external hardware standard.

OPTICS:

A .16" thick clear tempered glass lens protects LEDs. Placement, spacing, and aperture of LEDs provides a 120 degree spread of light.

ELECTRICAL:

High-efficiency LEDs. 0-10V dimming standard for a dimming range of 100% to 10%. Input voltage is MVOLT (120-277V). Suitable for 50/60Hz. Luminaire Surge Protection Level: Designed to withstand up to 6kV/3kA per ANSI C82.77-5-2015. L90 > 54,000 hours.

CONTROLS:

Sensors may be field installed utilizing the wiring box accessory that is attached to the top of the fixture in the field. Recommended Acuity Brands sensors: [SBOR](#) and [rSBOR](#).

INSTALLATION:

Corrosion resistant 1/4" NPT eye bolt with 1/2" thick loop and 6' cord with dimming lead provided for easy installation. 3/4" reducer available for stem or hook mounting. Optional surface mount bracket allows flexibility by adjusting in 15 degree increments for a total range of 150 degrees. Also capable of accepting 3/4" stem or hook. Recommended hooks include HKMG and HKF.

LISTINGS:

CSA certified to US and Canadian safety standards. Wet location listed. For use under covered ceilings. See Operational Data Chart for temperature ratings. IP65 rated. Certified to meet NSF Splash Zone 2.

DesignLights Consortium® (DLC) Premium qualified product.

WARRANTY:

5-year limited warranty. This is the only warranty provided and no other statements in this specification sheet create any warranty of any kind. All other express and implied warranties are disclaimed. Complete warranty terms located at:

www.acuitybrands.com/support/customer-support/terms-and-conditions

Note: Actual performance may differ as a result of end-user environment and application. All values are design or typical values, measured under laboratory conditions at 25 °C. Specifications subject to change without notice.

Dimensions

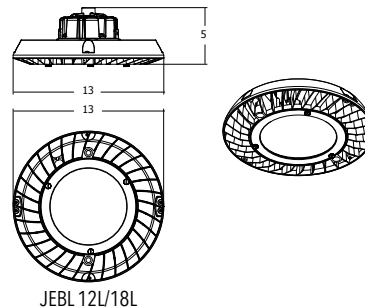

All dimensions are inches (centimeters) unless otherwise indicated.

Accessories: Order as separate catalog number.

JEBLCLR1 M4	Polycarbonate clear reflector for 12L
JEBLDALR1 M4	Diffuse Aluminum reflector for 12L
JEBLMTG ADAPTER M12	3/4" reducer
JEBSMB1 M6	Surface mount bracket for 12L
JCBLS120	Safety cable 120"
JCBLS240	Safety cable 240"
JEBLWBK18 M6	Wiring box kit for sensor attachment for use with 12L fixtures
JEBLWG1 M6	Lens wireguard for 12L ¹
HKF	Female aluminum hook
HKMG	Male grommeted aluminum hook

NOTES

1. Compatible with optional reflectors.

